

CartStop Systems Protector Installation Instructions

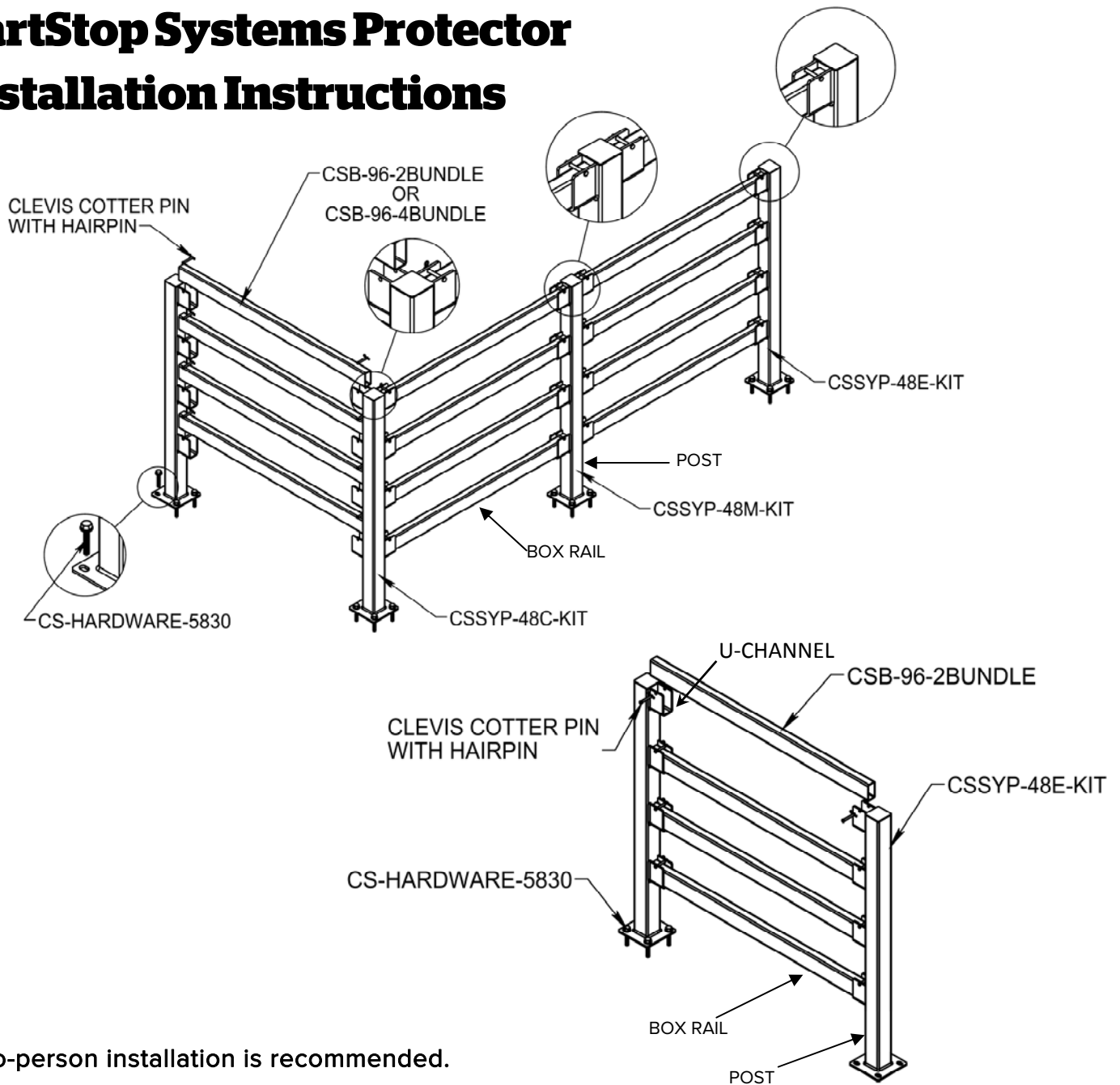

Two-person installation is recommended.

Tools Required:

- Hammer Drill
- 1/2" Carbide Bit
- Tape Measure
- Pencil
- Allen Wrench Set
- Rubber Mallet
- Straight Edge
- Brush and Dust Pan
- Chalk Line
- Plumb Bob
- Carpenter Square or Framing Square

Systems Protector Assembly:

CartStop Systems Protector can be installed in a variety of configurations. Depending upon the desired configuration, each kit is made up of end rail posts (CSSYP-48E-KIT), corner rail posts (CSSYP-48C-KIT) and/or middle rail posts (CSSYP-48M-KIT) that support parallel box rail bars (CSB-96-2 or 4BUNDLE).

Each end of the box rail bar (CSB-96-2 or 4BUNDLE) fits into a U-channel on each of post and is locked into place with a clevis cotter pin.

Each post must be fixed to the ground with four self-threading concrete anchors.

Box rails may be cut to create a custom width. See step 2 for more detail.

Step 1: Layout and Positioning

Position two rail posts, with the U-channels facing inward, in front of the equipment or system that you wish to protect.

The rail posts should be placed $\frac{3}{4}$ " to the outside of the equipment you are trying to protect.

Measure $7\frac{5}{8}$ " from the front and the perimeter of the equipment or system that needs protecting and snap a chalk line.

Line up the front of the rail post base plate with the chalk line at $7\frac{5}{8}$ " as shown below.

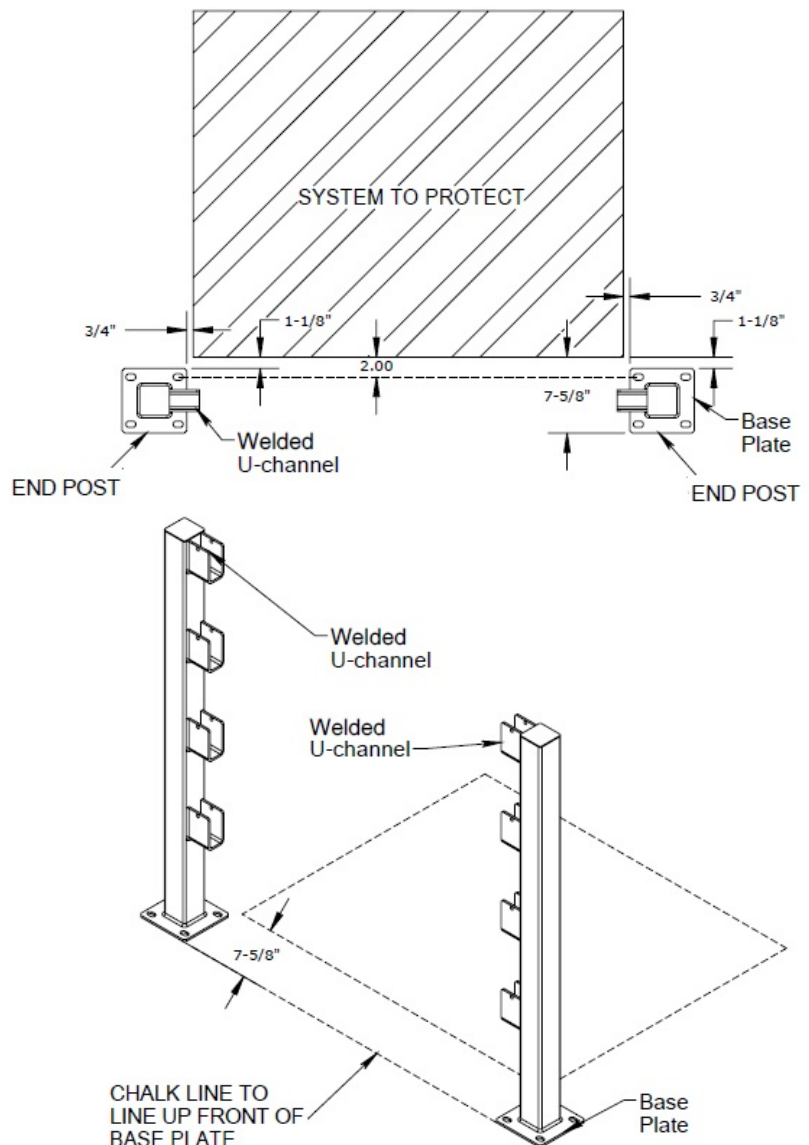

Step 2: Positioning Posts

Making sure that each rail post is squared and straight in its alignment, use a pencil or marker to mark the location of the anchor holes in the base of each base plate onto the floor.

Measure the width between the two rail posts. This will be the length required for each box rail to fit into the U-channels and fit flush against the rail posts.

NOTE: Box rail may be cut to custom lengths using a metal cutting chop saw or angle grinder with cut-off wheel. If the distance between the posts is less than the length of the box rail, bolt down the upright posts and then cut the box rail to fit between the posts.

CAUTION! THE EDGE OF THE CUT BOX RAIL WILL BE SHARP. DE-BUR WITH A METAL FILE OR ANGLE GRINDER.

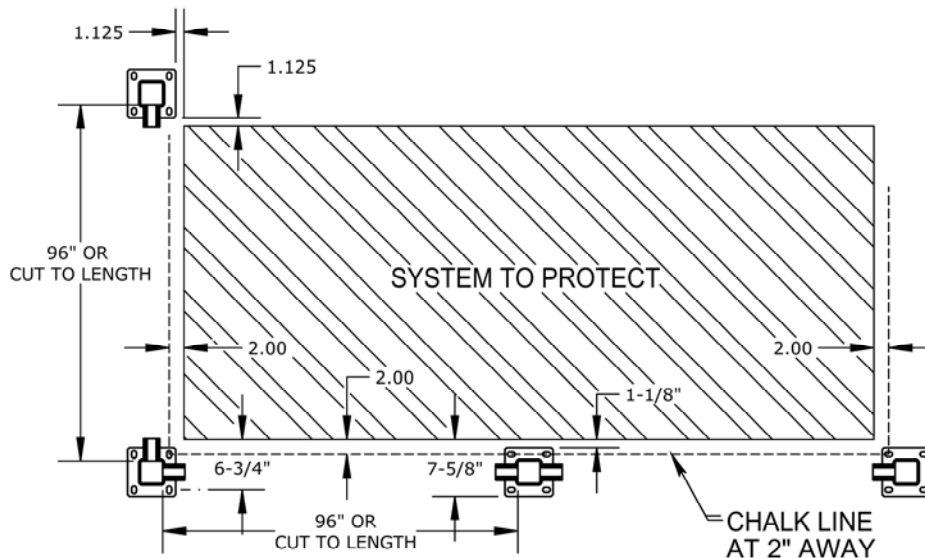
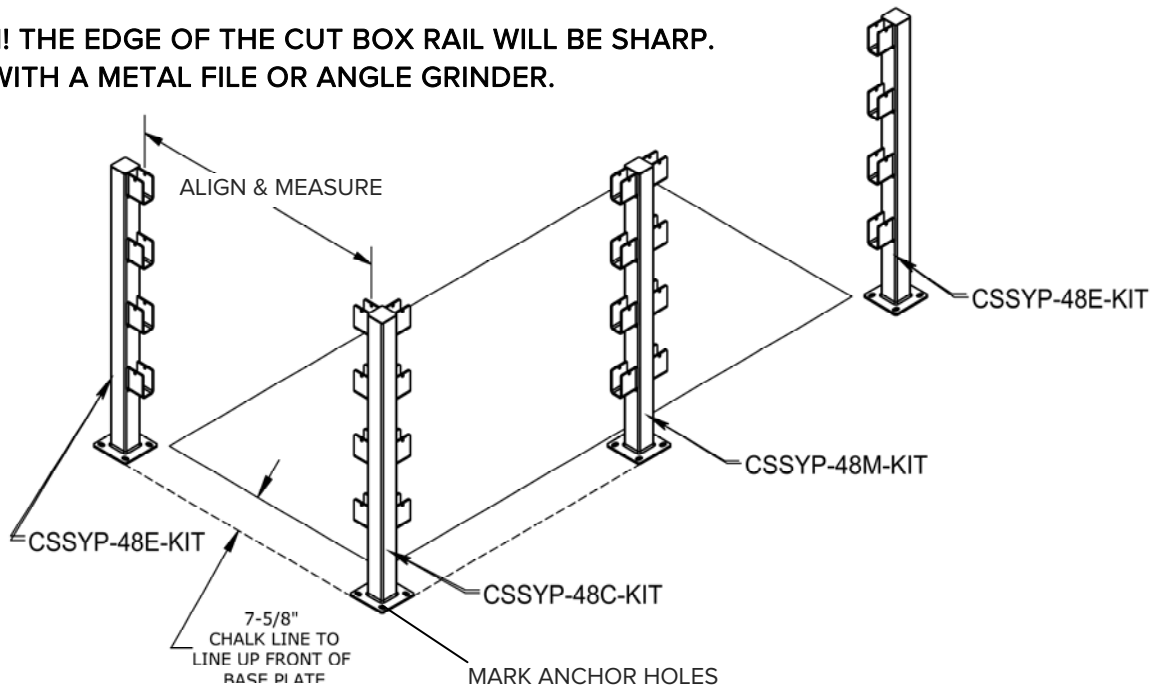

Step 3: Installing Posts

Remove posts and set aside. Use a hammer drill with ½" carbide concrete bit to drill each marked hole to a depth that is slightly longer than 3" (the length of the supplied concrete anchors). Remove dust and debris from the holes using a vacuum cleaner. Align rail posts over their respective drilled holes. Make sure box rail fits prior to fixing post to floor. Drive the concrete anchors through the holes in each base plate and into the floor using an impact driver with a 13/16" socket. The bottom of the concrete anchor heads should be flush with the base plates.

Step 4: Installing Box Rail

NOTE: It is strongly recommended that one complete section of two posts and their respective box rail bars are installed before progressing on to the next complete section.

Place the box rail into the U-channels on the respective posts then insert the clevis pin (Figure A.)

Secure the clevis pin to the U-channel with the provided hairpin (Figure B.)

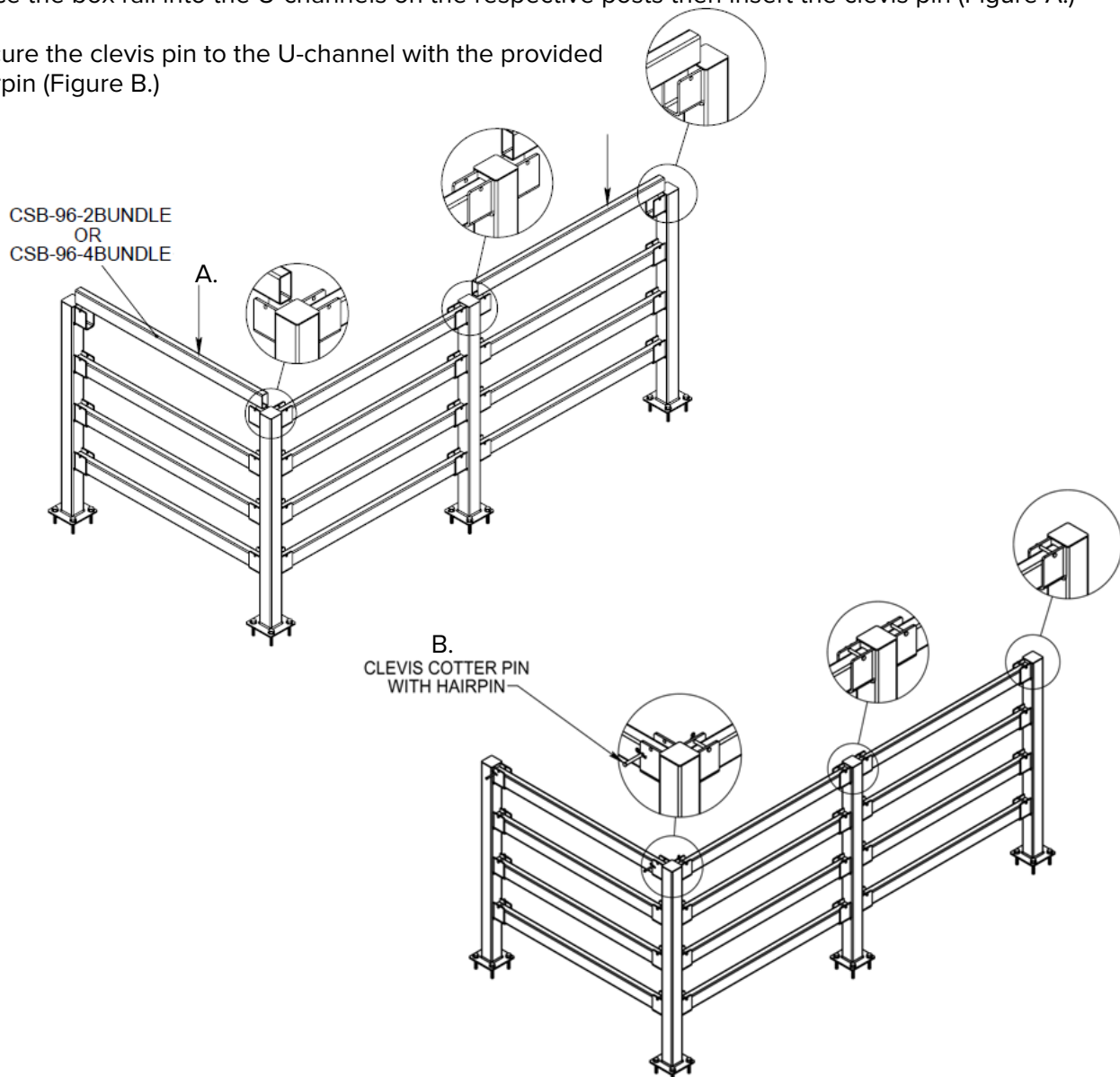

Step 5: Installation is Complete

